

Daikin Altherma 3 H HT
The quintessence of heat pump
Product catalogue



High temperature air-to-water heat pump
Heating, cooling and domestic hot water



reddot design award
winner 2019



EPRA-D series





Table of contents

Daikin Altherma 3 H HT F	10
Daikin Altherma 3 H HT ECH₂O.....	16
Daikin Altherma 3 H HT W	22
Thermal stores and tank.....	26
Thermal store	28
Domestic hot water tank.....	29
Daikin Altherma HPC.....	30
Madoka	34
Stand By Me.....	38
Combination table and options.....	42

Designed to withstand the coldest climate conditions



Made in Europe, for Europe

European weather can be tough sometimes. That's why we designed the Daikin Altherma 3 H HT.

Heating capacities are also maintained high by low ambient temperature thanks to genuine Daikin technology.

As the market leader, Daikin is always striving to make the most reliable and efficient heat pumps possible. Daikin developed the Bluevolution technology to achieve higher and greener performance. This technology is now part of all new products such as the Daikin Altherma 3 H HT. The Daikin Altherma 3 H HT is the first Daikin outdoor unit with a distinctive design. Its single fan reduces the noise level and its black front grill makes the unit fit into any environment.

All these dedicated components were specially developed in-house to make the Daikin Altherma 3 H HT unique.

Superior performance, renewable energy use, design and acoustic comfort. This is what the Quintessence of heat pump is all about.

BLUEvolution

The Bluevolution technology combines a specifically developed compressor and the R-32 refrigerant. Daikin is one of the pioneers in the world to launch heat pumps equipped with R-32. With a lower Global Warming Potential (GWP), the R-32 is equivalent in power to standard refrigerants, but achieves higher energy efficiency and lower CO₂ emissions.

Easy to recover and reuse, R-32 is the perfect solution for attaining the new European CO₂ emission targets.

R-32

Design and space-saving installation

Aside from the acoustic comfort, design is a decisive point nowadays. Specific attention was paid to making the outdoor unit blend in with your home.

The black front grill stretches horizontally making the fan inside invisible. The mat grey casing reflects the colour of the wall behind for more discretion. This unit received the IF and reddot design awards 2019.

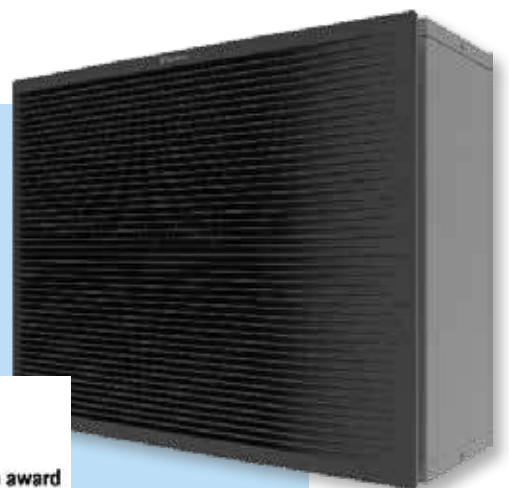

Meeting modern society's expectations



Silence rhymes with comfort

The Daikin Altherma 3 H HT has been designed to reduce its acoustic level and meet the expectations of today's society.

The Daikin Altherma 3 H HT offers greater flexibility by having a low sound mode. In standard sound mode, the unit produces a sound pressure of 38 dBA at 3 metres, so somewhere between birds chirping and the inside of a library. On the other hand, the low sound mode reduces by 3 dB(A) the sound pressure at 3 meters to reach 35 dB(A), representing a real reduction of half the sound level!

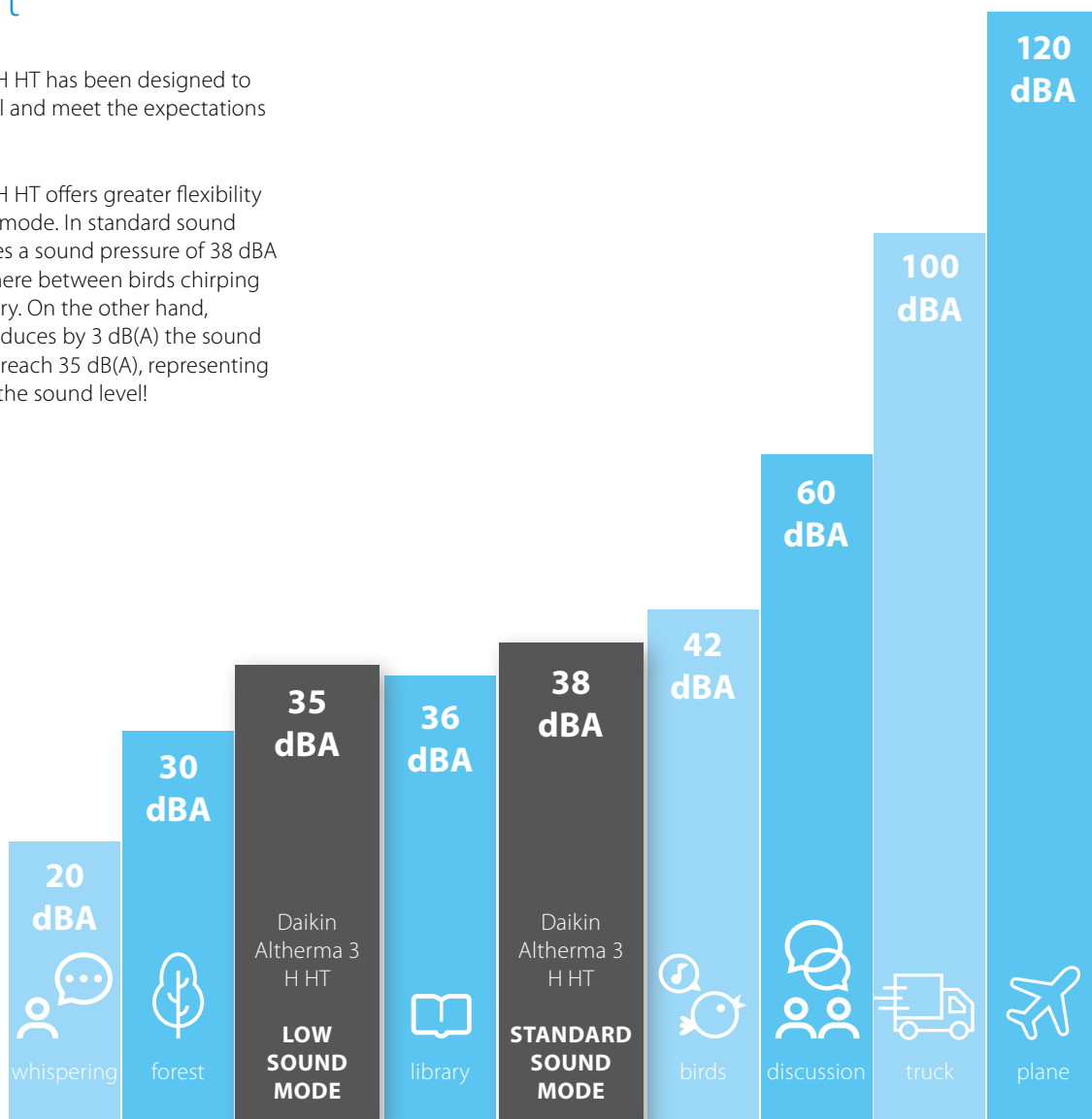

Innovation At the heart of our concerns

The Daikin Altherma 3 H HT is at top of low sound and heating performances thanks to dedicated developments. Several major components are designed to make this product reach the excellence such as a double injection compressor and a single fan even for large capacity units as well as a brand-new casing.

A redesigned casing

The black front grill made of horizontal lines is hiding the fan from view, reducing the perception of the sound produced by the unit.

The light grey casing is slightly reflecting the environment where the unit is installed, helping it to blend in in any decor.

This unique design already got design awards.



**reddot design award
winner 2019**

A single fan for high capacities

The single fan is slightly larger, replacing the usual double fan for high capacity units (14-16-18 kW).

The shape of the fan has also been reviewed to reduce the contact surface with air therefore lower the sound level by improving the air circulation.

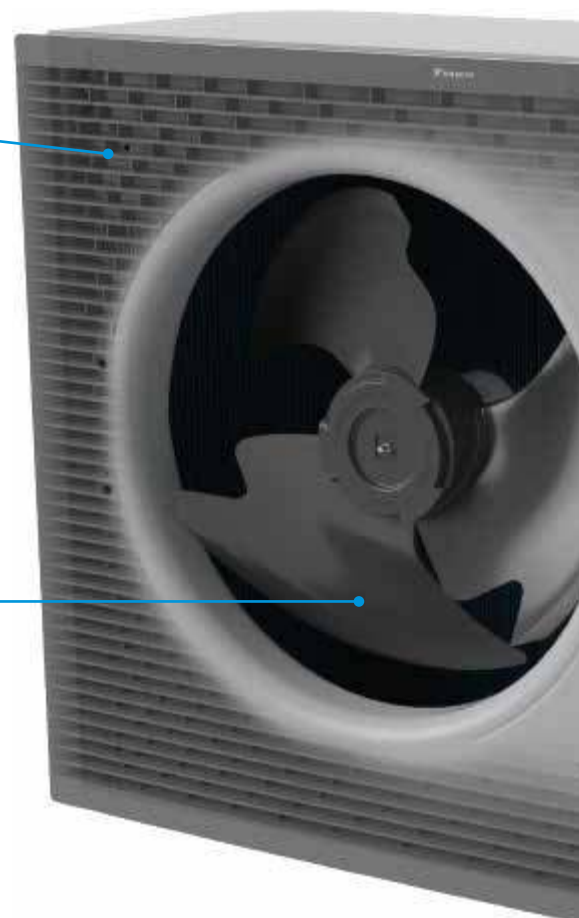

Compressor insulation and anti-vibration

To reduce the compressor sound power, several actions were taken in terms of absorption and insulation.

First, the compressor is surrounded by a 3-layer insulation made of air, insulation material and a metal box.

Regarding the absorption, the Daikin Altherma 3 H HT benefits from a double sound reduction by using a rubber pads between the bottom plate and the vibration plate under the compressor.

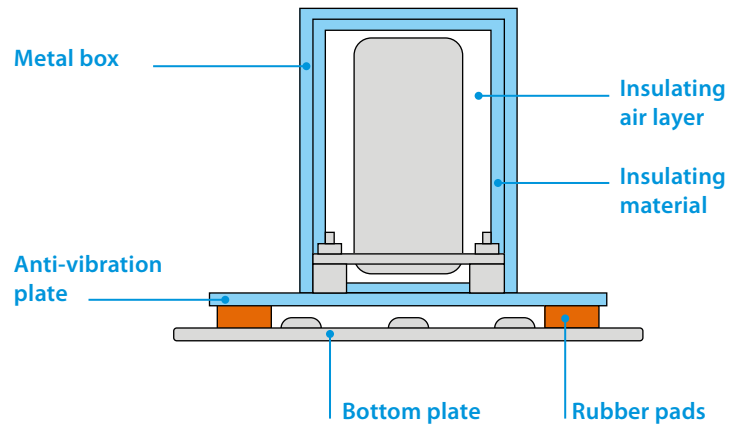

New double injection compressor

To make this product unique, Daikin Europe cooperated with Daikin Japan to develop top notch components. The Daikin Altherma 3 H HT compressor is able to deliver a high leaving water temperature of 70°C on its own.

Moreover, Daikin is a pioneer in launching heat pumps equipped with R-32. With a lower Global Warming Potential (GWP), the R-32 is equivalent in power to standard refrigerants, but achieves higher energy efficiency and lower CO₂ emissions. Easy to recover and reuse, R-32 is the perfect solution for attaining the new European CO₂ emission targets.

Unrivalled capacities

With these new developments, the Daikin Altherma 3 H HT reached the best performances illustrated in the energy labels:



One solution, multiple combinations

The Daikin Altherma 3 H HT range can be combined with three different indoor units to connect to the outdoor unit, offering specific features to ensure heating, cooling and domestic hot water in your home.

Outdoor unit

The outdoor unit is available in 3 classes 14-16-18 kW.

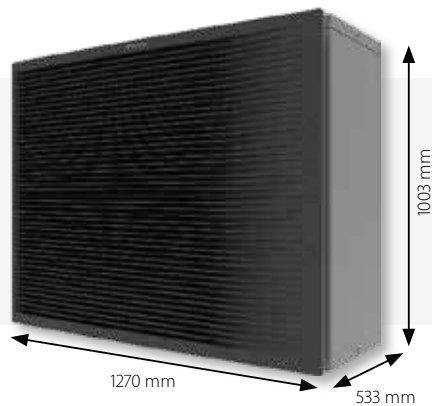

Integrated DHW stainless steel tank model

This model is a compact unit with a small footprint of 595x625mm. The unit is equipped with a tank of 180 or 230L to answer your domestic hot water demand.



Integrated ECH₂O DHW tank model

The ECH₂O unit is equipped with a thermal DHW tank of 300 or 500L that can be connected to thermal solar panels.



Wall mounted model

This model is the most compact unit but needs to be with a separate tank to deliver domestic hot water.



Get the best comfort

with the best functionalities

Choose from the Daikin "Three Pluses" the functionality that best fits your customer's needs. The indoor units come in 3 possible versions: heating only, reversible and bizone, giving you the opportunity to tailor your Daikin heating system.

+ Heating only model

The heating only model is standard in the Daikin product range and is available for all three indoor units. This means that your heating system provides space heating and domestic hot water.

+ Reversible model

If cooling is needed, all three indoors have dedicated reversible models. Reversible means that the system can invert its way of working and provide cooling instead of heating. The cooling function requires a underfloor piping system or fan coil units.

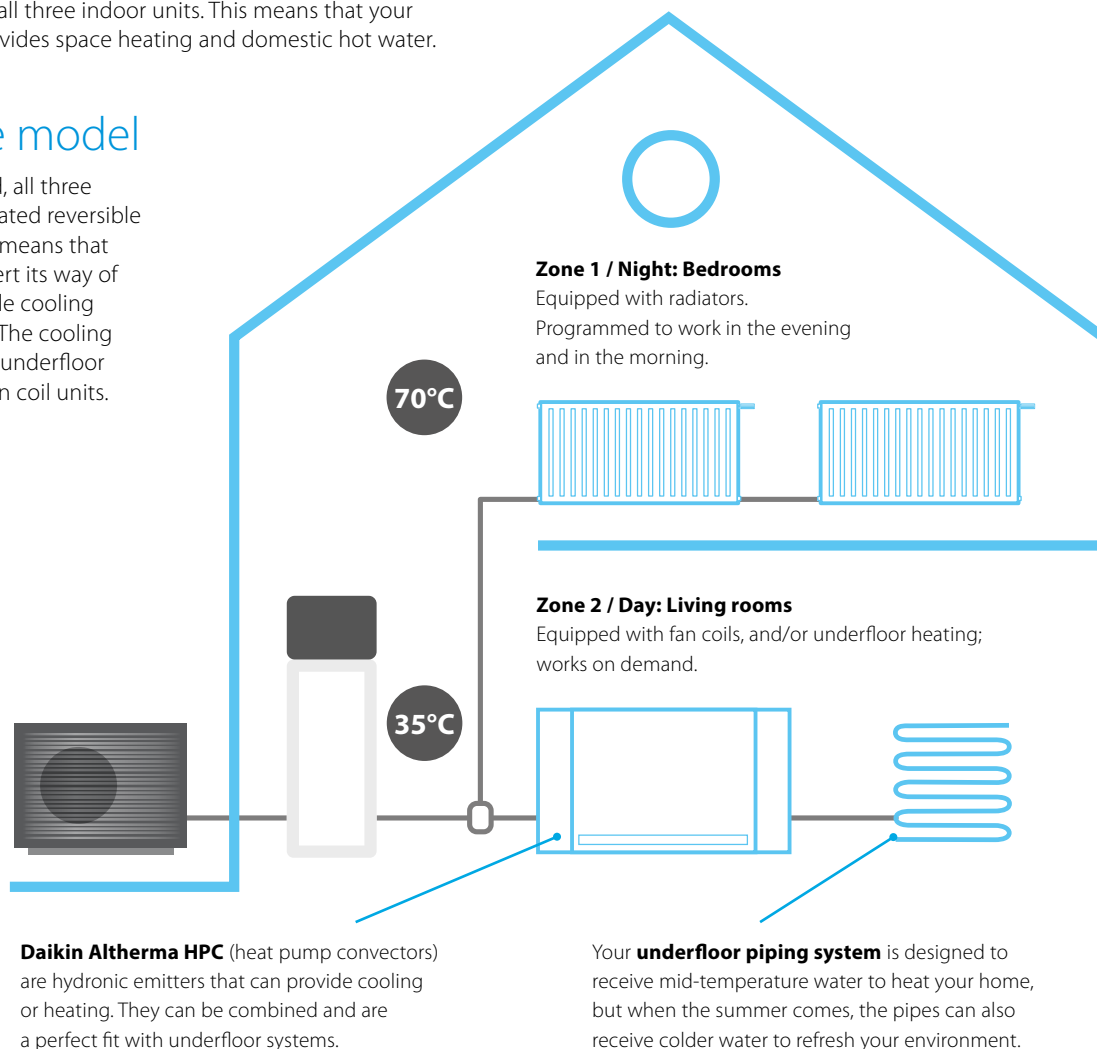

+ Bizone model

The integrated floor standing model also has a dedicated bizone model: you can choose two independent zones with different emitters that need a different temperature level in different rooms (example: underfloor system in the living room and radiators in the bedroom upstairs).

The 2 zones can also be managed independently: deactivate heating on the first floor during the day in order to reduce over consumption.



Daikin Altherma 3 H HT F

Floor standing unit with integrated tank

Why choose Daikin floor standing unit with integrated domestic hot water tank?

The Daikin Altherma 3 floor standing unit is the ideal system **to deliver heating, domestic hot water and cooling** for renovation or large new built.

All in one system to save installation space and time

- › A combined stainless steel domestic hot water tank of 180 or 230 L and heatpump ensures a faster installation compared to traditional systems.
- › Inclusion of all hydraulic components means no third party components are required.
- › PCB board and hydraulic components are located in the front for easy access
- › Small installation footprint of 595 x 625 mm
- › Integrated back-up heater choice of 6, 9 kW models are available
- › Dedicated bi-zone models allowing temperature monitoring for 2 zones.

Heating and cooling

Domestic hot water



Underfloor heating

All-in one design

Reduces the installation footprint and height

Compared to the traditional split version for a wall mounted indoor unit and a separate domestic hot water tank, the integrated indoor unit greatly reduces the installation space required.

With a small footprint of 595 x 625 mm, the integrated indoor unit has a similar footprint when compared to other household appliances.

For installation projects, almost no side clearance is necessary as the piping is located at the top of the unit.

With an installation height of 1,65 m for an 180 L tank and 1,85 m for a 230 L tank, the required installation height is less than 2m.

The compactness of the integrated indoor unit is emphasised by its sleek design and modern look, easy blending in with other household appliances.

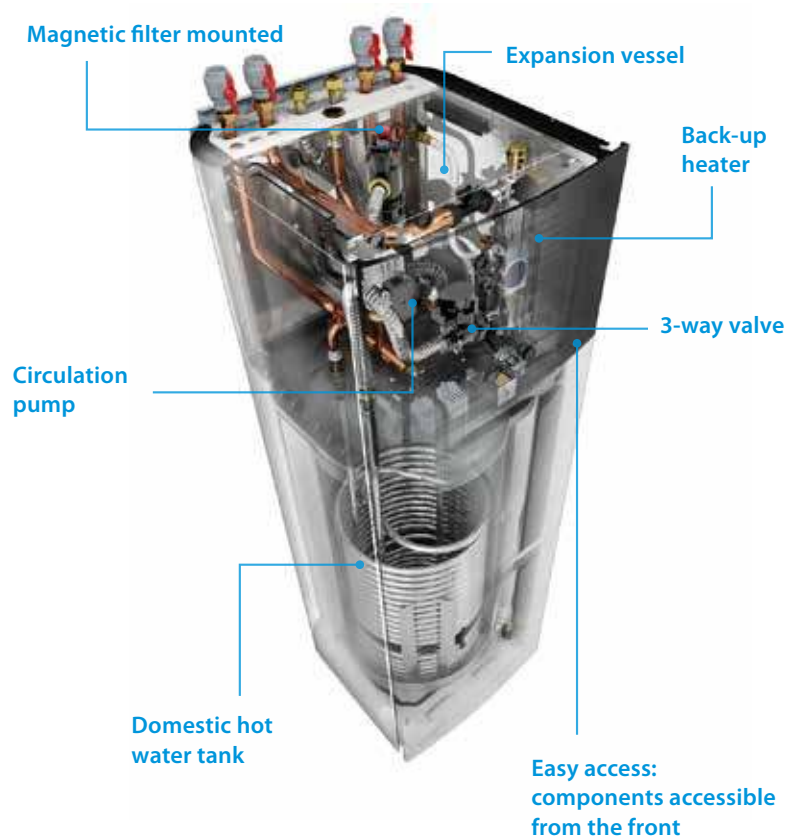

Advanced user interface



The Daikin Eye

The intuitive Daikin eye shows you in real time the status of your system.

Blue is perfect! Should the eye turn red, an error has occurred.

Quick to configure

Log in and you'll be able to completely configure the unit via the new MMI in less than 10 steps. You can even check if the unit is ready for use by running test cycles!

Easy operation

Work super-fast with the new MMI. It's super easy to use with just a few buttons and 2 navigational knobs.

Beautiful design

The MMI was especially designed to be very intuitive. The high contrasted colour screen delivers stunning and practical visuals that really help you as installer or service engineer.

Integrated indoor unit



Daikin Altherma 3 H HT F

Floor standing air to water heat pump for heating and hot water

- › A combined stainless steel domestic hot water tank of 180 or 230L and heat pump for easy installation
- › Inclusion of all hydraulic components means no third party components are required
- › PCB board and hydraulic components are located in the front for easy access
- › Small installation footprint of 595 x 625 mm
- › Integrated back-up heater of 6 or 9 kW
- › Heat pump operation down to -28°C



Efficiency data				ETVH + EPRA		16S18D6V(G)/D9W(G) + 14DV/W	16S23D6V(G)/D9W(G) + 14DV/W	16S18D6V(G)/D9W(G) + 16DV/W	16S23D6V(G)/D9W(G) + 16DV/W	16S18D6V(G)/D9W(G) + 18DV/W	16S23D6V(G)/D9W(G) + 18DV/W
Space heating	Average climate water outlet 55°C	General	SCOP	3,58 / 3,57							
		ηs (Seasonal space heating efficiency)	%	140							
	Seasonal space heating eff. class			A++							
	Average climate water outlet 35°C	General	SCOP	4,51 / 4,48							
ηs (Seasonal space heating efficiency)		%	177 / 176								
Seasonal space heating eff. class			A+++								
Domestic hot water heating	General	Declared load profile		L	XL	L	XL	L	XL	L	XL
	Average climate	COPdhw		2,62 / 2,51	2,61 / 2,55	2,62 / 2,51	2,61 / 2,55	2,62 / 2,51	2,61 / 2,55	2,62 / 2,51	2,61 / 2,55
		ηwh (water heating efficiency)	%	110 / 106	108 / 107	110 / 106	108 / 107	110 / 106	108 / 107	110 / 106	108 / 107
	Water heating energy efficiency class			A							
Indoor Unit				ETVH		16S18D6V(G)/D9W(G)	16S23D6V(G)/D9W(G)	16S18D6V(G)/D9W(G)	16S23D6V(G)/D9W(G)	16S18D6V(G)/D9W(G)	16S23D6V(G)/D9W(G)
Casing	Colour	White + Black									
	Material	Precoated sheet metal									
Dimensions	Unit	HeightxWidthxDepth	mm	1,650x595x625	1,850x595x625	1,650x595x625	1,850x595x625	1,650x595x625	1,850x595x625	1,650x595x625	1,850x595x625
Weight	Unit		kg	109	118	109	118	109	118	109	118
Tank	Water volume		l	180	230	180	230	180	230	180	230
	Maximum water temperature		°C	70							
	Maximum water pressure		bar	10							
	Corrosion protection			Pickling							
Operation range	Heating	Water side	Min.~Max.	°C	15 ~ 70						
	Domestic hot water	Water side	Max.	°C	63						
Sound power level	Nom.		dBA	44							
Sound pressure level	Nom.		dBA	30							
Outdoor Unit				EPRA		14DV3/W1	16DV3/W1	18DV3/W1			
Dimensions	Unit	HeightxWidthxDepth	mm	1003x1270x533							
Weight	Unit		kg	146/151							
Compressor	Quantity			1							
	Type			Hermetically sealed scroll compressor							
Operation range	Cooling		Min.~Max.	°CDB	10 ~ 43						
	Heating		Min.~Max.	°CDB	-28 ~ 35						
	Domestic hot water		Min.~Max.	°CDB	-28 ~ 35						
Refrigerant	Type			R-32							
	GWP			675							
	Charge		kg	4,20							
	Charge		TCO ₂ Eq	2,84							
	Control			Expansion valve							
Sound power level (at 1 meter)	Nom.			54							
Sound pressure level	Nom.			43,0				48,0			
Power supply	Name/Phase/Frequency/Voltage		Hz/V	V3/1~/50/230 / W1/3~/50/400							
Current	Recommended fuses		A	32/16							

Daikin Altherma 3 H HT F

Floor standing air to water heat pump for **heating, cooling and hot water**

- › A combined stainless steel domestic hot water tank of 180 or 230L and heat pump for easy installation
- › Inclusion of all hydraulic components means no third party components are required
- › PCB board and hydraulic components are located in the front for easy access
- › Small installation footprint of 595 x 625 mm
- › Integrated back-up heater of 6, 9 kW
- › Heat pump operation down to -28°C



Efficiency data				ETVX + EPRA		16S18D6V(G)/D9W(G) + 14DV/W	16S23D6V(G)/D9W(G) + 14DV/W	16S18D6V(G)/D9W(G) + 16DV/W	16S23D6V(G)/D9W(G) + 16DV/W	16S18D6V(G)/D9W(G) + 18DV/W	16S23D6V(G)/D9W(G) + 18DV/W	
Space heating	Average climate water outlet 55°C	General	SCOP	3,62 / 3,63								
		ηs (Seasonal space heating efficiency)	%	142								
	Average climate water outlet 35°C	General	SCOP	4,57								
		ηs (Seasonal space heating efficiency)	%	180								
Domestic hot water heating				Declared load profile		L	XL	L	XL	L	XL	
Average climate	Average climate	COPdhw		2,62 / 2,51	2,61 / 2,55	2,62 / 2,51	2,61 / 2,55	2,62 / 2,51	2,61 / 2,55	2,62 / 2,51	2,61 / 2,55	
		ηwh (water heating efficiency)		%	110 / 106	108 / 107	110 / 106	108 / 107	110 / 106	108 / 107	110 / 106	108 / 107
		Water heating energy efficiency class			A							
Indoor Unit				ETVX		16S18D6V(G)/D9W(G)	16S23D6V(G)/D9W(G)	16S18D6V(G)/D9W(G)	16S23D6V(G)/D9W(G)	16S18D6V(G)/D9W(G)	16S23D6V(G)/D9W(G)	
Casing	Colour	White + Black										
	Material	Precoated sheet metal										
Dimensions	Unit	HeightxWidthxDepth	mm	1,650x595x625	1,850x595x625	1,650x595x625	1,850x595x625	1,650x595x625	1,850x595x625	1,650x595x625	1,850x595x625	
Weight	Unit		kg	109	118	109	118	109	118	109	118	
Tank	Water volume		l	180	230	180	230	180	230	180	230	
	Maximum water temperature		°C	70								
	Maximum water pressure		bar	10								
	Corrosion protection			Pickling								
Operation range	Heating	Water side	Min.~Max.	°C								
	Cooling	Water side	Min.~Max.	°C								
	Domestic hot water	Water side	Max.	°C								
Sound power level	Nom.		dBA	44								
Sound pressure level	Nom.		dBA	30								
Outdoor Unit				EPRA		14DV3/W1	16DV3/W1	18DV3/W1				
Dimensions	Unit	HeightxWidthxDepth	mm	1003x1270x533								
Weight	Unit		kg	146/151								
Compressor	Quantity			1								
	Type			Hermetically sealed scroll compressor								
Operation range	Cooling	Min.~Max.	°CDB	10 ~ 43								
	Heating	Min.~Max.	°CDB	-28 ~ 35								
	Domestic hot water	Min.~Max.	°CDB	-28 ~ 35								
Refrigerant	Type			R-32								
	GWP			675								
	Charge		kg	4,20								
	Charge		TCO ₂ Eq	2,84								
	Control			Expansion valve								
Sound power level (at 1 meter)	Nom.			54								
Sound pressure level	Nom.			43,0				48,0				
Power supply	Name/Phase/Frequency/Voltage		Hz/V	V3/1~/50/230 / W1/3~/50/400								
Current	Recommended fuses		A	32/16								

Daikin Altherma 3 H HT F

Floor standing integrated with **two different temperature zones monitoring**

- › A combined stainless steel domestic hot water tank of 180 or 230L and heat pump for easy installation
- › Inclusion of all hydraulic components means no third party components are required
- › PCB board and hydraulic components are located in the front for easy access
- › Small installation footprint of 595 x 625 mm
- › Integrated back-up heater of 6 or 9 kW
- › Heat pump operation down to -28°C



Efficiency data				ETVZ + EPRA	16S18D6V/D9W + 14DV/W	16S23D6V/D9W + 14DV/W	16S18D6V/D9W + 16DV/W	16S23D6V/D9W + 16DV/W	16S18D6V/D9W + 18DV/W	16S23D6V/D9W + 18DV/W
Space heating	Average climate water outlet 55°C	General	SCOP	3,58 / 3,57						
			ηs (Seasonal space heating efficiency) %	140						
	Seasonal space heating eff. class			A++						
	Average climate water outlet 35°C	General	SCOP	4,51 / 4,48						
ηs (Seasonal space heating efficiency) %			177 / 176							
Seasonal space heating eff. class			A+++							
Domestic hot water heating	General	Declared load profile		L	XL	L	XL	L	XL	
		Average COPdhw	2,62 / 2,51	2,61 / 2,55	2,62 / 2,51	2,61 / 2,55	2,62 / 2,51	2,61 / 2,55		
	ηwh (water heating efficiency) %	110 / 106	108 / 107	110 / 106	108 / 107	110 / 106	108 / 107			
	Water heating energy efficiency class		A							
Indoor Unit				ETVZ	16S18D6V/D9W	16S23D6V/D9W	16S18D6V/D9W	16S23D6V/D9W	16S18D6V/D9W	16S23D6V/D9W
Casing	Colour	White + Black								
	Material	Precoated sheet metal								
Dimensions	Unit	HeightxWidthxDepth	mm	1,650x595x625	1,850x595x625	1,650x595x625	1,850x595x625	1,650x595x625	1,850x595x625	
Weight	Unit	kg								
Tank	Water volume	l								
	Maximum water temperature	°C								
	Maximum water pressure	bar								
	Corrosion protection	Pickling								
Operation range	Heating	Water side	Min.~Max.	°C						
	Domestic hot water	Water side	Max.	°C						
Sound power level	Nom.	dBA								
Sound pressure level	Nom.	dBA								
Outdoor Unit				EPRA	14DV3/W1	16DV3/W1	18DV3/W1			
Dimensions	Unit	HeightxWidthxDepth	mm	1003x1270x533						
Weight	Unit	kg								
Compressor	Quantity	1								
	Type	Hermetically sealed swing compressor								
Operation range	Cooling	Min.~Max.	°CDB							
	Domestic hot water	Min.~Max.	°CDB							
Refrigerant	Type	R-32								
	GWP	675								
	Charge	kg								
	Charge	TCO ₂ Eq								
	Control	Expansion valve								
Sound power level (at 1 meter)	Nom.	54								
Sound pressure level	Nom.	43,0							48,0	
Power supply	Name/Phase/Frequency/Voltage			Hz/V						
Current	Recommended fuses			A						



Daikin Altherma 3 H HT ECH₂O

Floor standing unit with integrated ECH₂O tank

The Daikin Altherma high temperature split integrated ECH₂O is renowned for its ability to maximise renewable energy sources to provide the ultimate comfort in heating, domestic hot water and cooling

Intelligent storage management

- › The unit is 'Smart Grid' ready to take advantage of low energy tariffs and efficiently store thermal energy for space heating and domestic hot water
- › Continuous heating during defrost mode and use of stored heat for space heating (500l tank only)
- › Electronic management of both heat pump and ECH₂O thermal store maximises energy efficiency, as well as convenient heating and domestic hot water
- › Achieves the highest standards for water sanitation
- › Uses more renewable energy with solar connection

Innovative and high-quality tank

- › Lightweight plastic tank
- › No corrosion, anode, scale or lime deposits
- › Contains impact resistant polypropylene inner and outer walls filled with high-grade insulation foam to reduce heat losses to a minimum

Combinable with other heat sources

- › The bivalent option allows heat from other sources such as oil, gas or pellet-fired boilers to be stored in the solar system, further lowering energy consumption

ECH₂O

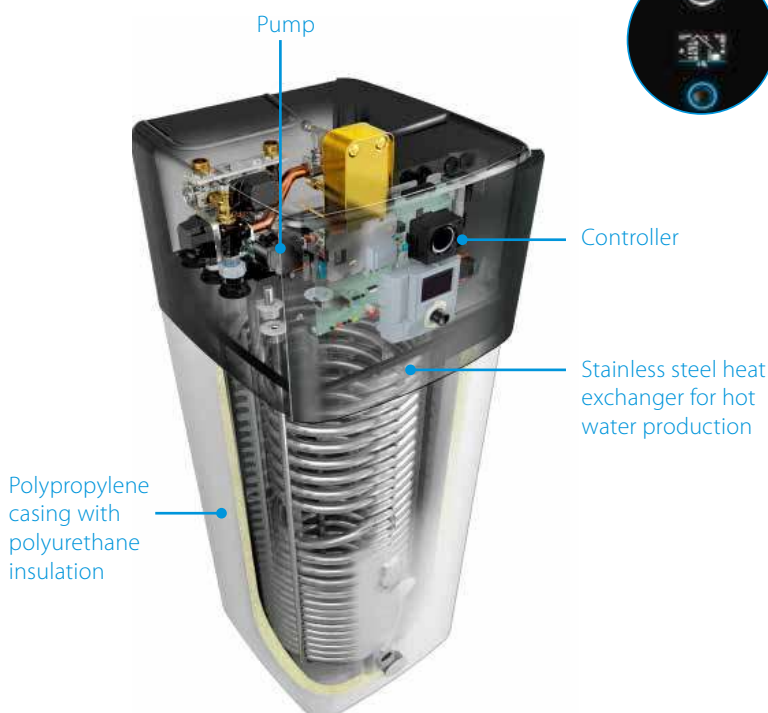

Advanced user interface

The Daikin-Eye

The intuitive Daikin eye shows you in real time the status of your system. Blue is perfect! Should the eye turn red, an error has occurred.

Quick to configure

Log in and you'll be able to completely configure the unit in less than 10 steps. You can even check if the unit is ready for use by running test cycles!

Easy operation

The user interface works really fast thanks to its icon-based menus.

Beautiful design

The interface was especially designed to be very intuitive. The high contrasted colour screen delivers stunning and practical visuals that really help you as installer or service engineer.

ECH₂O thermal store range: additional hot water comfort

Combine your indoor unit with a thermal store to achieve the ultimate comfort at home.

- › Fresh water principle: receive domestic hot water on demand while eliminating the risk of contamination and sedimentation
- › Optimal domestic hot water performance: the low temperature evolution enables high tapping performance
- › Fit for the future: possibility to integrate with renewable solar energy and other heat sources, e.g. fireplace
- › Lightweight and robust build of the unit combined with the cascade principle offers flexible installation options

Built for small and large homes, customers can choose between a pressureless and a pressurised hot water system.

Pressureless (drain-back) solar system (ETSH-D, ETSX-D)

- › The solar collectors are only filled with water when sufficient heating is provided by the sun
- › The pumps in the control and pump unit switch on briefly and fill the collectors with storage tank water
- › After filling, water circulation is maintained by the remaining pump

Pressurised solar system (ETSXB-D, EHSXB-D)

- › System is filled with heat transfer fluid with the correct amount of antifreeze to avoid freezing in winter
- › System is pressurised and sealed

Monthly energy consumption of an average detached house

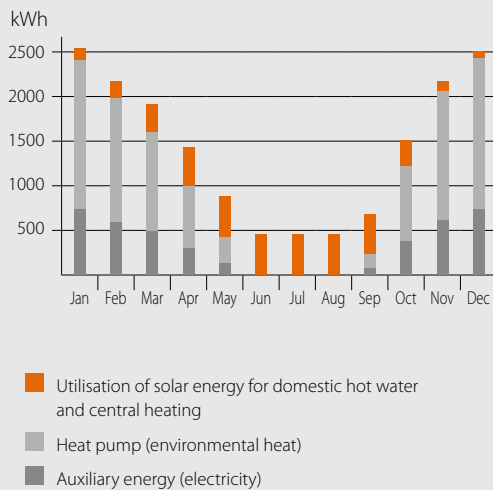

System diagram: Integrated solar unit

- 1 Use of solar energy for domestic hot water and central heating
- 2 External heat pump unit
- 3 Solar thermal collectors
- 4 Solar pump station

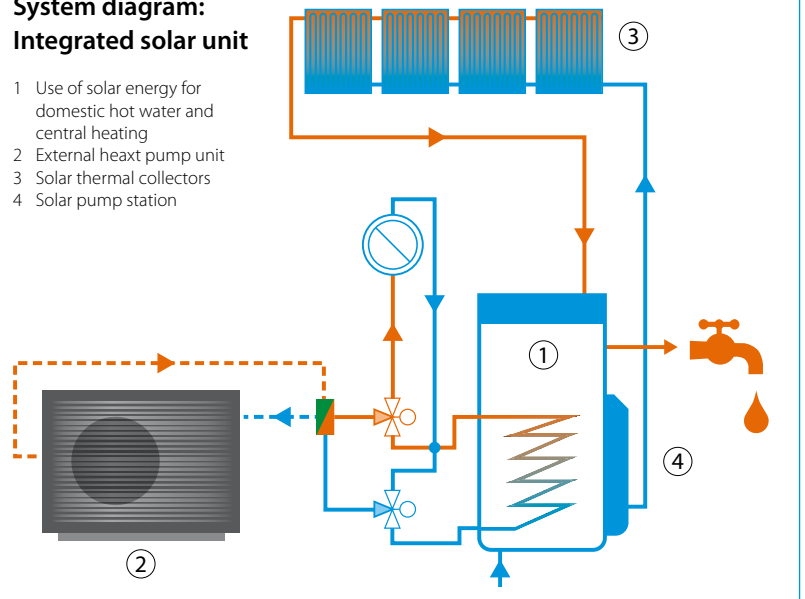

Daikin Altherma 3 H HT ECH₂O

Floor standing air-to-water heat pump for heating and hot water with thermal solar support

- › Integrated solar unit, offering top comfort in heating and hot water
- › Maximum use of renewable energy: uses heat pump technology for heating and solar support for space heating and domestic hot water production
- › Fresh water principle: hygienic water, with no need for thermal legionella disinfection
- › Maintenance-free tank: no corrosion, anode, scale or lime deposits, and no loss of water through safety valve
- › Solar support of domestic hot water with pressureless (drain-back) solar system
- › Heat loss is reduced to a minimum thanks to the high quality insulation
- › App control possible for managing heating, hot water and cooling operation
- › Heat pump operation down to -28°C
- › Possible to connect to photovoltaic solar panels to provide energy for your heat pump



up to **A+++** **A** **70°C** **R-32**

Efficiency data				ETSH + EPRA	16P30D + 14DV/W	16P50D + 14DV/W	16P30D + 16DV/W	16P50D + 16DV/W	16P30D + 18DV/W	16P50D + 18DV/W
Space heating	Average climate water outlet 55°C	General	SCOP	3,58 / 3,57						
			η _s (Seasonal space heating efficiency)	140						
	Average climate water outlet 35°C	General	SCOP	4,51 / 4,48						
			η _s (Seasonal space heating efficiency)	177 / 176						
Domestic hot water heating	General	Average climate	Declared load profile	A+++						
			COP _{dhw}	2,38	2,75 / 2,67	2,38	2,75 / 2,67	2,38	2,75 / 2,67	
	Average climate	General	η _{wh} (water heating efficiency)	101	115 / 111	101	115 / 111	101	115 / 111	
			Water heating energy efficiency class	A						
Indoor Unit				ETSH	16P30D	16P50D	16P30D	16P50D	16P30D	16P50D
Casing	Colour	Traffic white (RAL9016) / Dark grey (RAL7011)								
	Material	Impact resistant polypropylene								
Dimensions	Unit	HeightxWidthxDepth	mm	1891x590x615			1896x785x785		1891x590x615	1896x785x785
Weight	Unit		kg	77			94		77	94
Tank	Water volume		l	294			477		294	477
	Maximum water temperature		°C	85						
Operation range	Heating	Ambient	Min.~Max.	-28 ~ 35						
		Water side	Min.~Max.	15 ~ 70						
	Domestic hot water	Ambient	Min.~Max.	°CDB -28 ~ 35						
		Water side	Min.~Max.	°C 10 ~ 63						
Sound power level	Nom.		dBA	45,6						
Sound pressure level	Nom.		dBA	32,8						
Outdoor Unit				EPRA	14DV3/W1	16DV3/W1	18DV3/W1			
Dimensions	Unit	HeightxWidthxDepth	mm	1003x1270x533						
Weight	Unit		kg	146 / 151						
Compressor	Quantity			1						
	Type			Hermetically sealed swing compressor						
Operation range	Cooling	Min.~Max.	°CDB	-28 ~ 35						
	Domestic hot water	Min.~Max.	°CDB	-28 ~ 35						
Refrigerant	Type			R-32						
	GWP			675						
	Charge		kg	4,20						
	Charge		TCO ₂ Eq	2,84						
	Control			Expansion valve						
Sound power level (at 1 meter)	Nom.			54						
Sound pressure level	Nom.			43,0				48,0		
Power supply	Name/Phase/Frequency/Voltage		Hz/V	V3/1~/50/230 / W1/3~/50/400						
Current	Recommended fuses		A	32/16						

Daikin Altherma 3 H HT ECH₂O

Floor standing air-to-water heat pump for **bivalent heating and hot water** with thermal solar support

- › Integrated solar unit, offering top comfort in heating and hot water
- › Maximum use of renewable energy: uses heat pump technology for heating and solar support for space heating and domestic hot water production
- › Fresh water principle: hygienic water, with no need for thermal legionella disinfection
- › Maintenance-free tank: no corrosion, anode, scale or lime deposits, and no loss of water through safety valve
- › Bivalent system: combinable with a secondary heat source
- › Heat loss is reduced to a minimum thanks to the high quality insulation
- › App control possible for managing heating and hot water operation
- › Heat pump operation down to -28°C



Efficiency data				ETSHB-D + EPRA	18P30D + 14DV/W	16P50D + 14DV/W	18P30D + 16DV/W	18P50D + 16DV/W	18P30D + 18DV/W	18P50D + 18DV/W
Space heating	Average climate water outlet 55°C	General	SCOP	3,58 / 3,57						
			ηs (Seasonal space heating efficiency) Seasonal space heating eff. class	140 A++						
	Average climate water outlet 35°C	General	SCOP	4,51 / 4,48						
			ηs (Seasonal space heating efficiency) Seasonal space heating eff. class	177 / 176 A+++						
Domestic hot water heating	General	Declared load profile			XL					
	Average climate	COPdhw		2,38	2,58 / 2,75	2,38	2,58 / 2,75	2,38	2,58 / 2,75	
		ηwh (water heating efficiency) Water heating energy efficiency class		101	108 / 115	101	108 / 115	101	108 / 115	
				A						
Indoor Unit				ETSHB	16P30D	16P50D	16P30D	16P50D	16P30D	16P50D
Casing	Colour	Traffic white (RAL9016) / Dark grey (RAL7011)								
	Material	Impact resistant polypropylene								
Dimensions	Unit	HeightxWidthxDepth	mm	1891x590x615			1896x785x790		1891x590x615	1896x785x785
Weight	Unit		kg	79			100		79	100
Tank	Water volume		l	294			477		294	477
	Maximum water temperature		°C	85						
Operation range	Heating	Ambient	Min.~Max.	-28 ~ 35						
		Water side	Min.~Max.	15 ~ 70						
	Domestic hot water	Ambient	Min.~Max.	-28 ~ 35						
		Water side	Min.~Max.	10 ~ 73						
Sound power level	Nom.		dBA	45.6						
Sound pressure level	Nom.		dBA	32.8						
Outdoor Unit				EPRA	14DV3/W1	16DV3/W1	18DV3/W1			
Dimensions	Unit	HeightxWidthxDepth	mm	1003x1270x533						
Weight	Unit		kg	146 / 151						
Compressor	Quantity			1						
	Type			Hermetically sealed swing compressor						
Operation range	Heating	Min.~Max.	°CDB	-28 ~ 35						
	Domestic hot water	Min.~Max.	°CDB	-28 ~ 35						
Refrigerant	Type			R-32						
	GWP			675						
	Charge		kg	4.20						
	Charge		TCO ₂ Eq	2,84						
	Control			Expansion valve						
Sound power level (at 1 meter)	Nom.			54						
Sound pressure level	Nom.			43,0				48,0		
Power supply	Name/Phase/Frequency/Voltage		Hz/V	V3/1~/50/230 / W1/3~/50/400						
Current	Recommended fuses		A	32/16						

Daikin Altherma 3 H HT ECH₂O

Floor standing air-to-water heat pump for heating, cooling and hot water with thermal solar support

- › Integrated solar unit, offering top comfort in heating, hot water and cooling
- › Maximum use of renewable energy: uses heat pump technology for heating and solar support for space heating and domestic hot water production
- › Fresh water principle: hygienic water, with no need for thermal legionella disinfection
- › Maintenance-free tank: no corrosion, anode, scale or lime deposits, and no loss of water through safety valve
- › Solar support of domestic hot water with pressureless (drain-back) solar system
- › Heat loss is reduced to a minimum thanks to the high quality insulation
- › App control possible for managing heating, hot water and cooling operation
- › Outdoor unit extracts heat from the outdoor air, even at -28°C
- › Possible to connect to photovoltaic solar panels to provide energy for your heat pump



up to

Efficiency data				ET SX + EPRA	16P30D + 14DV/W	16P50D + 14DV/W	16P30D + 16DV/W	16P50D + 16DV/W	16P30D + 18DV/W	16P50D + 18DV/W
Space heating	Average climate water outlet 55°C	General	SCOP	3,62 / 3,63						
			η _s (Seasonal space heating efficiency)	142						
	Seasonal space heating eff. class	A++								
Domestic hot water heating	Average climate water outlet 35°C	General	SCOP	4,57						
			η _s (Seasonal space heating efficiency)	180						
	Seasonal space heating eff. class	A+++								
Domestic hot water heating	General	Declared load profile	COP _{dhw}	2,38	2,75 / 2,67	2,38	2,75 / 2,67	2,38	2,75 / 2,67	
			η _{wh} (water heating efficiency)	101	115 / 111	101	115 / 111	101	115 / 111	
			Water heating energy efficiency class	A						
			XL							

Indoor Unit				ET SX	16P30D	16P50D	16P30D	16P50D	16P30D	16P50D
Casing	Colour	Traffic white (RAL9016) / Dark grey (RAL7011)								
	Material	Impact resistant polypropylene								
Dimensions	Unit	HeightxWidthxD	mm	1891x590x615	1896x785x785	1891x590x615	1896x785x785	1891x590x615	1896x785x785	
	Unit	Weight	kg	77	94	77	94	77	94	
Tank	Water volume	l		294	477	294	477	294	477	
	Maximum water temperature	°C		85						
Operation range	Heating	Ambient	Min.~Max.	-28~35						
		Water side	Min.~Max.	15~70						
	Cooling	Ambient	Min.~Max.	°CDB 10~43						
		Water side	Min.~Max.	°C 5~22						
	Domestic hot water	Ambient	Min.~Max.	°CDB -28~35						
		Water side	Min.~Max.	°C 10~63						
Sound power level	Nom.	dBA	45,6							
Sound pressure level	Nom.	dBA	32,8							

Outdoor Unit				EPRA	14DV3/W1	16DV3/DW1	18DV3/DW1	
Dimensions	Unit	HeightxWidthxD	mm	1003x1270x533				
	Unit	Weight	kg	146/151				
Compressor	Quantity	1						
	Type	Hermetically sealed swing compressor						
Operation range	Heating	Min.~Max.	°CDB	-28 ~ 43				
	Cooling	Min.~Max.	°CDB	10 ~ 43				
	Domestic hot water	Min.~Max.	°CDB	-25 ~ 35				
Refrigerant	Type	R-32						
	GWP	675,0						
	Charge	kg	4,20					
	Charge	TCO ₂ Eq	2,84					
Sound power level (at 1 meter)	Nom.	Expansion valve						
		54						
Sound pressure level	Nom.	43,0						
Power supply	Name/Phase/Frequency/Voltage	V3/1~/50/230 / W1/3~/50/400						
Current	Recommended fuses	A 32/16						

Daikin Altherma 3 H HT ECH₂O

Floor standing air-to-water heat pump for **bivalent heating, cooling and hot water** with thermal solar support

- › Integrated solar unit, offering top comfort in heating and hot water
- › Maximum use of renewable energy: uses heat pump technology for heating and solar support for space heating and domestic hot water production
- › Fresh water principle: hygienic water, with no need for thermal legionella disinfection
- › Maintenance-free tank: no corrosion, anode, scale or lime deposits, and no loss of water through safety valve
- › Bivalent system: combinable with a secondary heat source
- › Heat loss is reduced to a minimum thanks to the high quality insulation
- › App control possible for managing heating and hot water operation



Efficiency data				ETSXB-D + EPRA								
				16P30D + 14DV/W	16P50D + 14DV/W	16P30D + 16DV/W	16P50D + 16DV/W	16P30D + 18DV/W	16P50D + 18DV/W			
Space heating	Average climate water outlet 55°C	General	SCOP	3,62 / 3,63								
			ηs (Seasonal space heating efficiency) Seasonal space heating eff. class	142 A++								
	Average climate water outlet 35°C	General	SCOP	4,57								
			ηs (Seasonal space heating efficiency) Seasonal space heating eff. class	180 A+++								
Domestic hot water heating	General	Declared load profile			XL							
	Average climate	COPdhw		2,38	2,58 / 2,75	2,38	2,58 / 2,75	2,38	2,58 / 2,75			
		ηwh (water heating efficiency) Water heating energy efficiency class		101	108 / 115	101	108 / 115	101	108 / 115	A		
Indoor Unit				ETSXB-D	16P30D	16P50D	16P30D	16P50D	16P30D	16P50D		
Casing	Colour	Traffic white (RAL9016) / Dark grey (RAL7011)										
	Material	Impact resistant polypropylene										
Dimensions	Unit	HeightxWidthxDepth	mm	1891x590x615	1896x785x785	1891x590x615	1896x785x785	1891x590x615	1896x785x785			
	Unit		kg	79	100	79	100	79	100			
Tank	Water volume		l	294	477	294	477	294	477			
	Maximum water temperature		°C	85								
Operation range	Heating	Ambient	Min.~Max.	-25~35								
		Water side	Min.~Max.	15~70								
	Cooling	Ambient	Min.~Max.	°CDB 10~43								
		Water side	Min.~Max.	°C 5~22								
	Domestic hot water	Ambient	Min.~Max.	°CDB -28~35								
		Water side	Min.~Max.	°C 10~63								
Sound power level	Nom.		dBA	45,6								
Sound pressure level	Nom.		dBA	32,8								
Outdoor Unit				EPRA	14DV3/DW1	16DV3/W1	18DV3/W1					
Dimensions	Unit	HeightxWidthxDepth	mm	1003x1270x533								
	Unit		kg	146/151								
Compressor	Quantity			1								
	Type			Hermetically sealed swing compressor								
Operation range	Heating	Min.~Max.	°CDB	-28 ~ 35								
	Cooling	Min.~Max.	°CDB	10 ~ 43								
	Domestic hot water	Min.~Max.	°CDB	-25 ~ 35								
Refrigerant	Type			R-32								
	GWP			675,0								
	Charge		kg	4,20								
	Charge		TCO ₂ Eq	2,84								
	Control			Expansion valve								
Sound power level (at 1 meter)	Nom.			54								
Sound pressure level	Nom.			43,0				48,0				
Power supply	Name/Phase/Frequency/Voltage		Hz/V	V3/1~/50/230 / W1/3~/50/400								
Current	Recommended fuses		A	32/16								

This page contains preliminary data.

Daikin Altherma 3 H HTW Wall mounted unit

Why choose Daikin wall mounted unit?

The Daikin Altherma 3 split wall mounted unit offers heating and cooling with high flexibility for a quick and easy installation, with an optional connection to deliver domestic hot water.

High flexibility for installation and domestic hot water connection

- › Inclusion of all hydraulic components means no third party components are required
- › PCB board and hydraulic components are located in the front for easy access
- › Compact dimensions allows for small installation space, as almost no side clearances are required
- › The unit's sleek design blends in with other household appliances
- › Combine with a stainless steel or ECH₂O thermal store

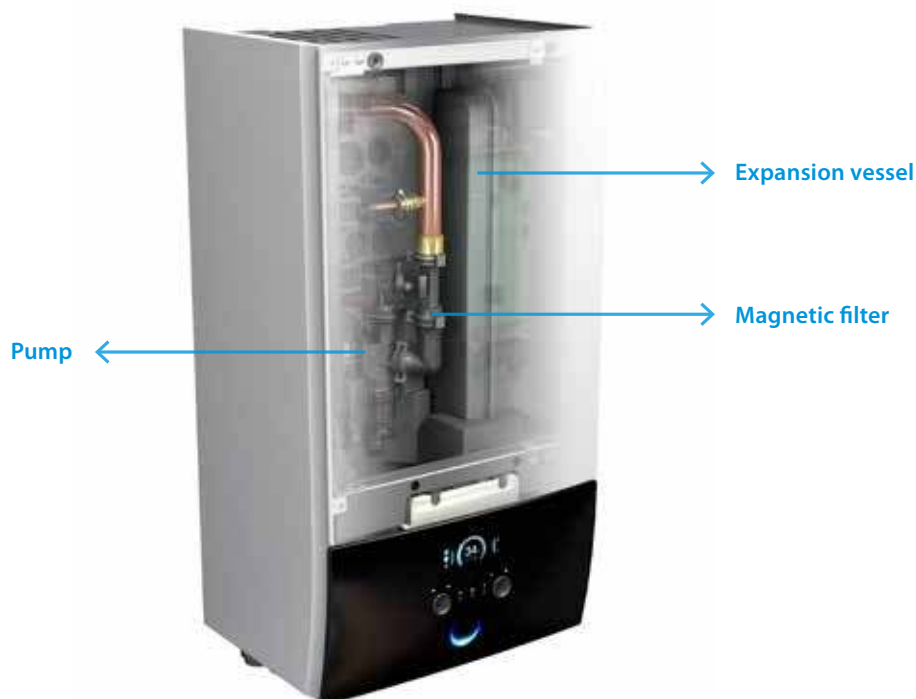

Flexibility in providing domestic hot water

If the end user requires hot water and installation height is limited, a separate stainless steel tank provides the required installation flexibility.

ECH₂O thermal store range: additional hot water comfort

Combine your wall mounted unit with a thermal store for additional hot water comfort.

- › Fresh water principle: receive domestic hot water on demand while eliminating the risk of contamination and sedimentation
- › Optimal domestic hot water performance: with high tapping performance
- › Fit for future possibility to integrate with renewable solar energy and other heat sources, e.g. fireplace
- › Lightweight and robust build on the unit combined with cascade principle offers flexible installation options



Flexibility in providing space heating

Daikin Altherma 3 H HT W is the perfect choice in case the end user is looking for space heating or cooling while domestic hot water is provided by another system.

Example of installation with a stainless steel domestic hot water tank.



Daikin Altherma 3 H HT W

Wall mounted **heating only** air-to-water heat pump

- › Inclusion of all hydraulic components means no third party components are required
- › PCB board and hydraulic components are located in the front for easy access
- › Compact dimensions allows for small installation space, as almost no side clearances are required
- › The unit's sleek design blends in with other household appliances
- › Combine with a stainless steel tank or ECH₂O thermal store
- › Heat pump operation down to -28°C



up to

Efficiency data				ETBH + EPRA	16D6V + 14DV/DW	16D9W + 14DV/DW	16D6V + 16DV/W	16D9W + 16DV/W	16D6V + 18DV/DW	16D9W + 18DV/DW	
Space heating	Average climate water outlet 55°C	General	SCOP		3,58 / 3,57						
			η _s (Seasonal space heating efficiency)	%	140						
	Average climate water outlet 35°C	General	SCOP		4,51 / 4,48						
			η _s (Seasonal space heating efficiency)	%	177 / 176						
				Seasonal space heating eff. class	A++						
				Seasonal space heating eff. class	A+++						
Indoor Unit				ETBH	16D6V	16D9W	16D6V	16D9W	16D6V	16D9W	
Casing	Colour	White + Black									
	Material	Sheet metal									
Dimensions	Unit	HeightxWidthxDp	mm	840x440x390							
Weight	Unit	kg									
Operation range	Heating	Water side	Min.~Max.	°C	18 ~ 70						
	Domestic hot water	Water side	Min.~Max.	°C	25 ~ 80						
Sound power level	Nom.	dBa									
Sound pressure level	Nom.	dBa									
Outdoor Unit				EPRA	14DV3/DW1		16DV3/W1		18DV3/DW1		
Dimensions	Unit	HeightxWidthxDp	mm	1003x1270x533							
Weight	Unit	kg									
Compressor	Quantity	1									
	Type	Hermetically sealed swing compressor									
Operation range	Cooling	Min.~Max.	°CDB	-28 ~ 35							
	Domestic hot water	Min.~Max.	°CDB	-25 ~ 35							
Refrigerant	Type	R-32									
	GWP	675.0									
	Charge	kg									
	Charge	TCO ₂ Eq	2,84								
	Control	Expansion valve									
Sound power level (at 1 meter)	Nom.	54									
Sound pressure level	Nom.					43,0			48,0		
Power supply	Name/Phase/Frequency/Voltage	Hz/V			V3/1~/50/230 / W1/3~/50/400						
Current	Recommended fuses	A			32/16						

Daikin Altherma 3 H HT W

Wall mounted **reversible** air-to-water heat pump

- › Inclusion of all hydraulic components means no third party components are required
- › PCB board and hydraulic components are located in the front for easy access
- › Compact dimensions allows for small installation space, as almost no side clearances are required
- › The unit's sleek design blends in with other household appliances
- › Combine with a stainless steel tank or ECH₂O thermal store
- › Heat pump operation down to -28°C



up to

Efficiency data				ETBX + EPRA		16D6V + 014DV/W	16D9W + 14DV/W	16D6V + 16DV/W	16D9W + 16DV/W	16D6V + 18DV/W	16D9W + 18DV/W
Space heating	Average climate water outlet 55°C	General	SCOP	3,62 / 3,63							
			η _s (Seasonal space heating efficiency)	%	142						
	Average climate water outlet 35°C	General	SCOP	4,57							
			η _s (Seasonal space heating efficiency)	%	180						
			Seasonal space heating eff. class	A++							
			Seasonal space heating eff. class	A+++							
Indoor Unit				ETBX	16D6V	16D9W	16D6V	16D9W	16D6V	16D9W	
Casing	Colour	White + Black									
	Material	Sheet metal									
Dimensions	Unit	HeightxWidthxDepth	mm								
Weight	Unit	kg									
Operation range	Heating	Water side	Min.~Max.	°C							
	Cooling	Water side	Min.~Max.	°C							
	Domestic hot water	Water side	Min.~Max.	°C							
Sound power level	Nom.	dBA									
Sound pressure level	Nom.	dBA									
Outdoor Unit				EPRA	14DV3/DW1		16DV3/W1		18DV3/DW1		
Dimensions	Unit	HeightxWidthxDepth	mm								
Weight	Unit	kg									
Compressor	Quantity	1									
	Type	Hermetically sealed swing compressor									
Operation range	Cooling	Min.~Max.	°CDB								
	Heating	Min.~Max.	°CDB								
	Domestic hot water	Min.~Max.	°CDB								
Refrigerant	Type	R-32									
	GWP	675,0									
	Charge	kg									
	Charge	TCO ₂ Eq									
	Control	Expansion valve									
Sound power level (at 1 meter)	Nom.	54									
Sound pressure level	Nom.	43,0							48,0		
Power supply	Name/Phase/Frequency/Voltage		Hz/V								
Current	Recommended fuses		A								

Thermal stores and tank

Hot water heating installation options

Why choose a thermal store or domestic hot water tank?

Whether you only need hot water or you want to combine your hot water with solar systems, we offer you the best solutions to the highest levels of comfort, energy efficiency and reliability.



Thermal store



Stainless steel tank

Domestic hot water tank

Stainless steel tanks

Comfort

- › Available in 150, 180, 200, 250 and 300 litres in stainless steel EKHWS(U)-D

Efficiency

- › High-quality insulation keeps heat loss to a minimum
- › Efficient temperature heating: from 10°C to 50°C in only 60 minutes
- › Available as an integrated solution or separate tank

Reliability

- › At necessary intervals, the unit can heat up water up to 60°C to prevent the risk of bacteria growth



The ECH₂O thermal store range

ECH₂O thermal store: additional hot water comfort

Combine your monobloc with a thermal store to achieve the ultimate comfort at home.

- › Fresh water principle: receive domestic hot water on demand while eliminating the risk of contamination and sedimentation
- › Optimal domestic hot water performance: the low temperature evolution enables high tapping performance
- › Fit for the future: possibility to integrate with renewable solar energy and other heat sources, e.g. fireplace
- › Lightweight and robust build of the unit combined with the cascade principle offers flexible installation options

Built for small and large homes, customers can choose between a pressureless and a pressurised hot water system.

Efficiency

- › Fit for the future: maximise renewable energy sources
- › Intelligent Heat Storage Management: ensures continuous heating during defrost mode, and uses stored heat for space heating
- › High-quality insulation keeps heat loss to a minimum

Reliability

- › Maintenance-free tank: no corrosion, anode, scale or lime deposits, and no water loss through the safety valve

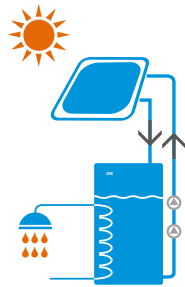

Drain-back solar system

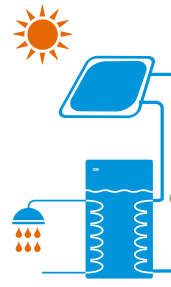

Pressurised solar system

Pressureless (drain-back) solar system

- › The solar collectors are only filled with water when sufficient heating is provided by the sun
- › The pumps in the control and pump unit switch on briefly and fill the collectors with storage tank water
- › After filling, water circulation is maintained by the remaining pump

Pressurised solar system

- › System is filled with heat transfer fluid with the correct amount of antifreeze to avoid freezing in winter
- › System is pressurised and sealed

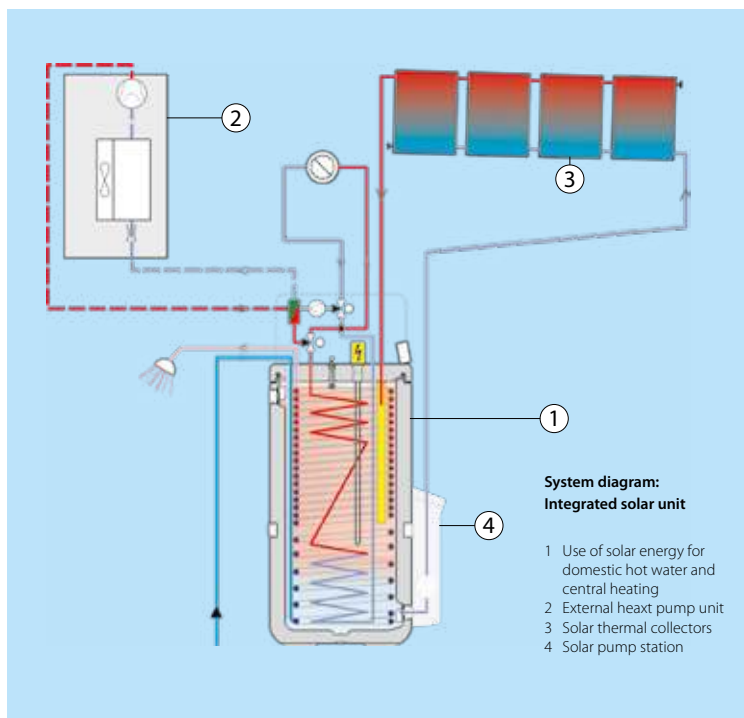

Monthly energy consumption of an average detached house

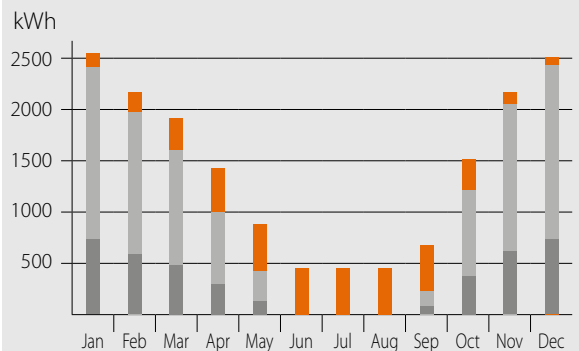

- Utilisation of solar energy for domestic hot water and central heating
- Heat pump (environmental heat)
- Auxiliary energy (electricity)

Thermal store

Plastic domestic hot water tank with solar support

- › Tank designed for connection with pressurised thermal solar system
- › Tank designed for connection with drainback thermal solar system
- › Available in 300 and 500 liters
- › Large hot water storage tank to provide domestic hot water at any time
- › Heat loss is reduced to a minimum thanks to the high quality insulation
- › Space heating support possible (500l tank only)



Accessory		EKHWP	300B	500B	300PB	500PB		
Casing	Colour	Traffic white (RAL9016) / Dark grey (RAL7011)						
	Material	Impact resistant polypropylene						
Dimensions	Unit	Width	mm	595	790	595	790	
		Depth	mm	615	790	615	790	
Weight	Unit	Empty	kg	58	82	58	89	
	Tank	Water volume	l	294	477	294	477	
	Material		Polypropylen					
	Maximum water temperature		°C	85				
	Insulation	Heat loss	kWh/24h	1.5	1.7	1.5	1.7	
	Energy efficiency class		B					
	Standing heat loss		W	64	72	64	72	
	Storage volume		l	294	477	294	477	
	Heat exchanger	Domestic hot water	Quantity	1				
Tube material			Stainless steel (DIN 1.4404)					
Face area			m ²	5.600	5.800	5.600	5.900	
Internal coil volume			l	27.1	28.1	27.1	28.1	
Operating pressure			bar	6				
Average specific thermal output			W/K	2,790	2,825	2,790	2,825	
Charging		Quantity	1					
		Tube material	Stainless steel (DIN 1.4404)					
		Face area	m ²	3	4	3	4	
		Internal coil volume	l	13	18	13	18	
		Average specific thermal output	W/K	1,300	1,800	1,300	1,800	
Pressurised solar		Average specific thermal output	W/K	-	-	390.00	840.00	
Auxiliary solar heating		Tube material	-		Stainless steel (DIN 1.4404)		-	
		Face area	m ²	-	1	-	-	1
		Internal coil volume	l	-	4	-	-	4
	Operating pressure	bar	-	3	-	-	3	
	Average specific thermal output	W/K	-	280	-	-	280	

Domestic hot water tank

Stainless steel domestic hot water tank

› Available in 150, 180, 200, 250 and 300 litres in stainless steel
EKHWS(U)-D



EKHWS(U)-D

Accessory		EKHWS	150(U)D3V3	180(U)D3V3	200(U)D3V3	250(U)D3V3	300(U)D3V3	
Casing	Colour		Neutral white					
	Material		Epoxy coated steel / Epoxy-coated mild steel					
Weight	Unit	kg	45	50	53	58	63	
	Empty							
Tank	Water volume	l	145	174	192	242	292	
	Material		Stainless steel (EN 1.4521)					
	Maximum water temperature	°C	75					
	Insulation Heat loss	kWh/24h	1.1	1.2	1.3	1.4	1.6	
	Energy efficiency class		B					
	Standing heat loss	W	45	50	55	60	68	
	Storage volume	l	145	174	192	242	292	
	Heat exchanger	Domestic hot water	Quantity	1				
		Tube material	Stainless steel (EN 1.4521)					
		Face area	m ²	1.050	1.400	1.800		
		Internal coil volume	l	4.9	6.5	8.2		
		Operating pressure	bar	10				
Booster heater	Capacity	kW	3					
Power supply	Phase/Frequency/Voltage	Hz/V	1~/50/230					

Daikin Altherma HPC Floor standing model



By providing cooling and heating, Daikin Altherma HPC is combinable with underfloor piping and can replace outdated radiators. The unit is available in three models (floor standing, wall mounted and concealed) and fits in any bedrooms or living rooms thanks to its silent operation.

What is a heat pump convector

The way a heat pump convector works is similar to a radiator, as both use convection to heat a room. A radiator creates convection by running water through its pipes. With a heat pump convector, a radiator's convection process is faster because there is a small fan behind it speeding up the heating cycle.

A heat pump convector creates the same room temperature as a traditional radiator, but with lower water temperatures in the radiator, and in the long run, contribute to direct energy savings for users.

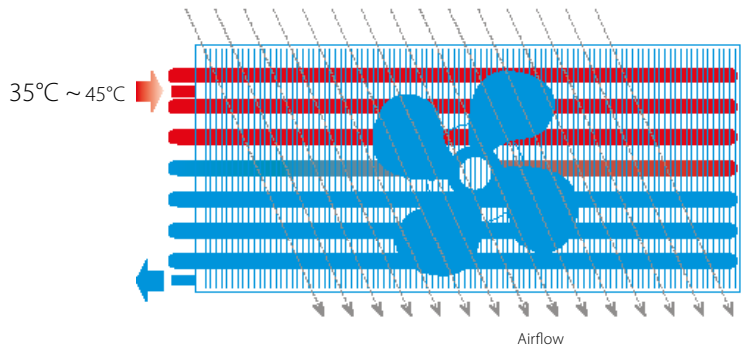

- > Optimized for new build houses
- > Can be selected at low water temperature (35°C) which makes it ideal for heat pump applications.

Slim design

The floor standing Daikin Altherma HPC measures 135 mm (depth), this heat pump can fit in any house or apartment.

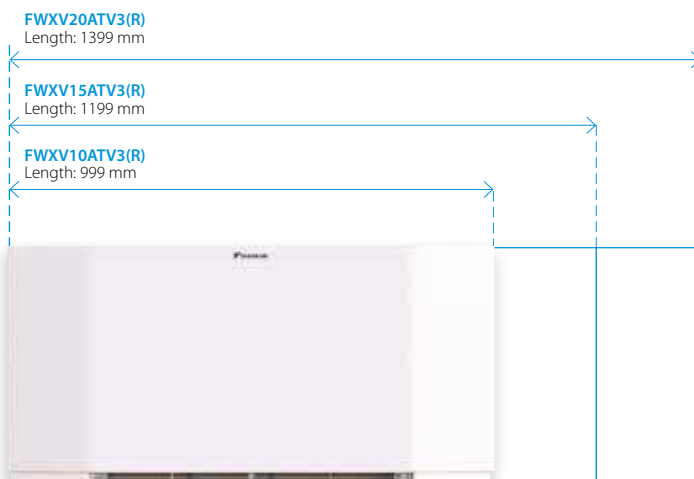

Fast and high capacity

The Daikin Altherma HPC combines the advantages of residential underfloor heating and radiators. It delivers high capacity heating or cooling faster and can be selected at ultra-low temperatures (35/30°C regime).





Discreet

As the unit reaches its set point, a continuous modulating fan gradually reduces its speed and creates less noise. The unit's sound pressure measures 25dB(A) at 1m when the fan is on a low-speed setting.



DC Inverter

Daikin Altherma HPC uses the latest technologies to consume less electricity down to 3W of standby power input.



Controls

Daikin offers a wide variety of controllers that are functional and have a great design.

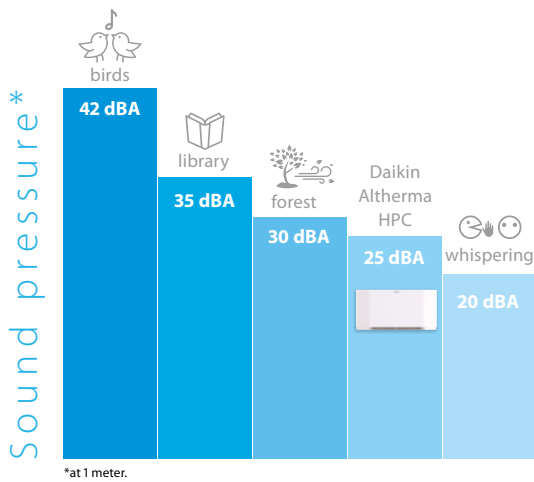

EKRTCTRL1



- > Built-in controller
- > Fully modulating
- > Multicolor display

EKRTCTRL2



- > Built-in controller
- > 4 speed selection

EKWHCTRL1



- > Wall controller
- > Fully modulating
- > In combination with EKWHCTRL0

EKPCBO



- > Built-in controller
- > ON/OFF
- > In combination with external thermostats



Modulated airflow

When there is less heating demand, the unit modulates its airflow to slow down the fan rate, and in the process, lowers the operational sound. A standard ON/OFF fan running simultaneously at full speed can increase sound pressure.



Perfect combination

This heat pump convector fits perfectly within the Daikin Altherma 3 range.

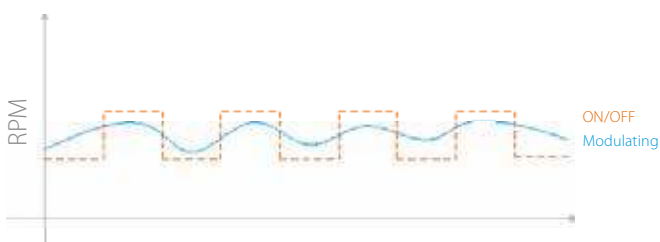

* Only applicable for EKRTCTRL1, EKWHCTRL1



Wall mounted model

Slim design

Daikin Altherma HPC is a compact unit made of a design metal casing including all valves. Its wall hung application saves space on the floor for furnitures and decoration.

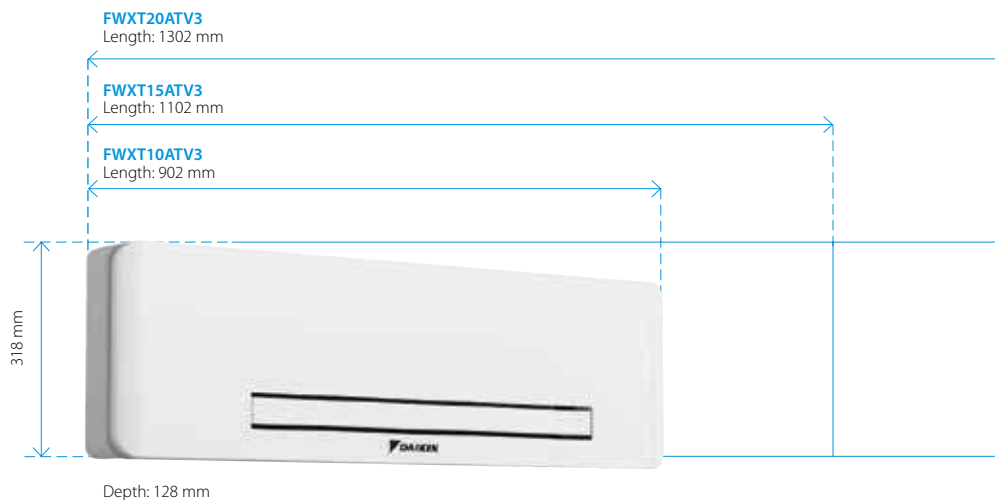

Controls

Fully modulating controller allowing remote control of the unit.

EKWHCTRL1



- > Wall controller
- > Fully modulating

Compactness



- 1 SLIM DEPTH**
Depth of 129 mm is an outstanding technical achievement that ensures the best fitting into any residential dwelling.
- 2 MORE SPACE FOR VALVES**
A special attention to the easiness of installation: the space for hydraulic valves is wide and easy accessible.
- 3 MODULATED AIRFLOW**
When there is less heating demand, the unit modulates its airflow to slow down the fan rate, and in the process, lowers the operational sound. A standard ON/OFF fan running simultaneously at full speed can increase sound pressure.

Concealed model



Slim design

Blue dimensions are for the front cover.

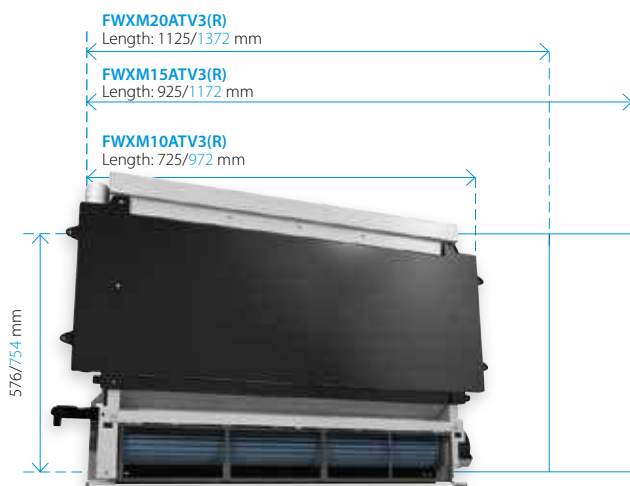

Depth: 128 mm



Flexible installation

Daikin Altherma HPC can be installed in 4 different ways, allowing you to install it in almost all conditions. The unit can be positioned horizontally or vertically. For horizontal, in ceiling installation, 3 different possibilities are offered:

- › Horizontal cover panel and vertical grill for air outlet
- › Horizontal intake grill and vertical grill for air outlet
- › Horizontal in and out grills for air outlet



Controls

EKWHCTRL1



- › Wall controller
- › Fully modulating
- › In combination with EKWHCTRL0



Madoka

The beauty of simplicity.



Silver
RAL 9006 (metallic)
BRC1HHDS



Black
RAL 9005 (matt)
BRC1HHDK



White
RAL9003 (glossy)
BRC1HHDW

User-friendly wired remote controller with premium design

Madoka combines refinement and simplicity

- › Sleek and elegant design
- › Intuitive touch-button control
- › Three colours to match any interior
- › Compact, measures only 85 x 85 mm



reddot award 2018
winner



BRC1HHDW / BRC1HHDS / BRC1HHDK

Madoka wired remote controller for Daikin Altherma 3

A new generation of user interface, redesigned and intuitive



› Replacing EKRUDAS for the Daikin Altherma 3 wall mounted and floor standing:



Intuitive control with a premium design:

The smooth curves of the Madoka controller offer a sleek, refined shape which is distinguished by its striking blue circular display. Presenting a clear visual reference with large easy to read numbers, the controller features are accessed through three touch buttons, which combine intuitive control with easy adjustability for an enhanced user experience.

Three colours to match any interior design:

No matter your interior design, Madoka will match it. Silver gives an additional touch to stand out in any interior or application, while Black is an ideal match for darker, stylish interiors. White offers a sleek, modern look.

Easily set operation parameters:

Setting and finetuning your controller is simple and helps you attain higher energy savings and more comfort. The system enables you to select the space operation mode (heating, cooling or automatic), set the desired room temperature and control the domestic hot water temperature.

Easy Update via Bluetooth:

It is strongly recommended that the user interface has the latest software version. To update the software or check if updates are available, you need a mobile device and the Madoka Assistant app. This app is available from Google Play and the Apple Store.



www.daikin.eu/madoka



Daikin Residential Controller

The Daikin Residential Controller application can, from any place at any time, control and monitor the status of your heating system and allows you to (*):

Monitor

- > The status of your system:
 - Room temperature
 - Requested room temperature
 - Operation mode
- > Energy consumption graphs (day, week, month)

Schedule

- > Schedule the room temperature and operation mode with up to **6 actions per day for 7 days**
- └ Enable **holiday mode**

Control

- > Operation mode
- └ Change the requested room temperature
- └ Change the requested domestic hot water temperature
- └ Powerful mode (fast heating domestic hot water)

*Availability of functions is depending on the system type, configuration and operation mode. App functionality is only available if both the Daikin system and the App have Internet connectivity.



App with intuitive lay-out

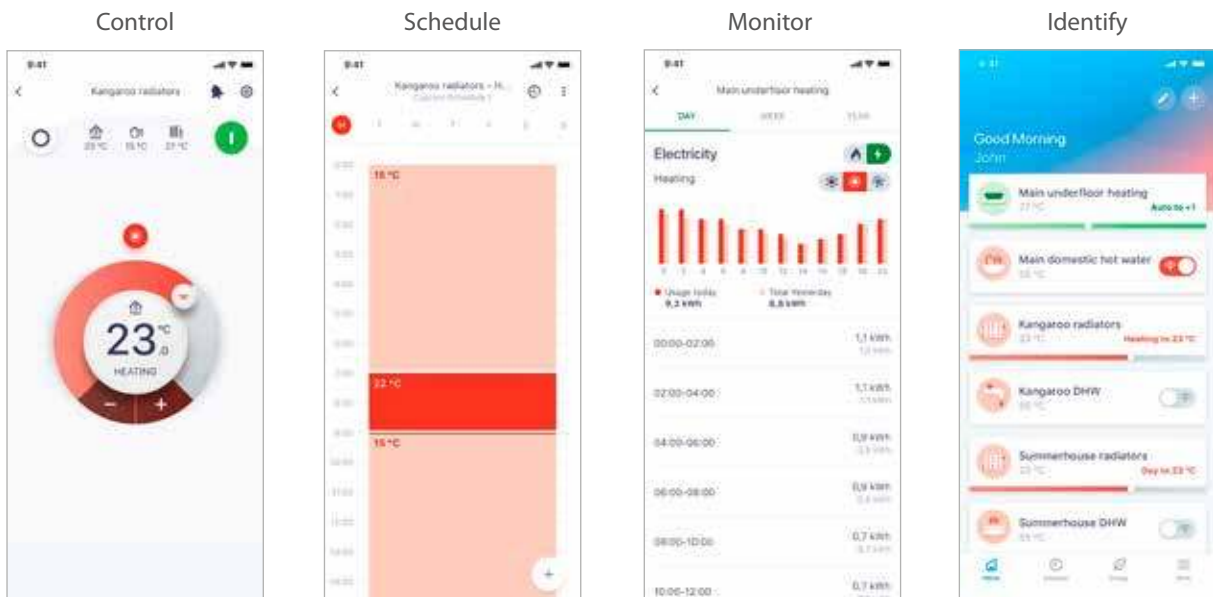

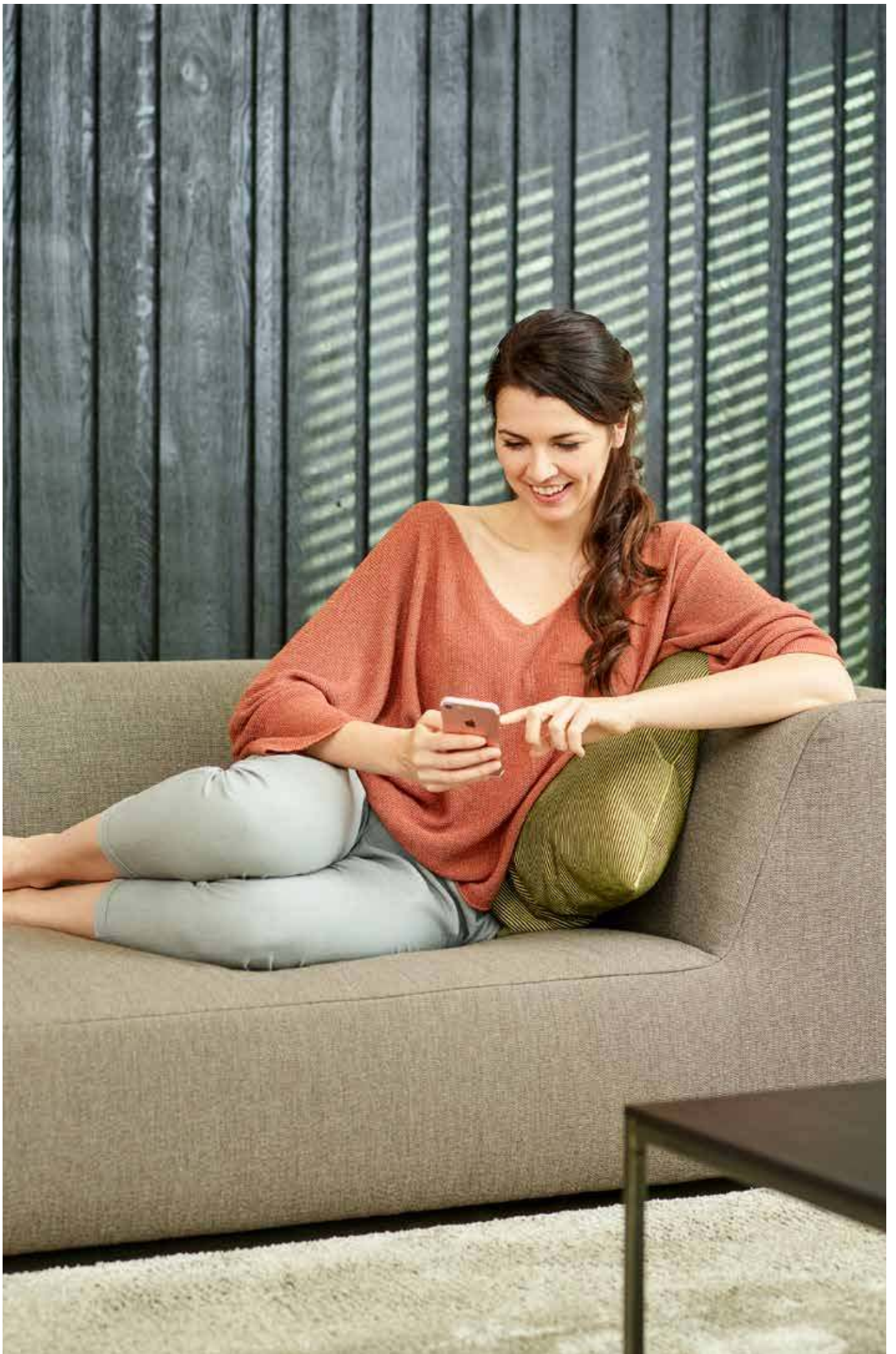

Stand By Me,

A journey to customer satisfaction

It's time to relax. With your customer's new Daikin installation and Stand By Me service programme, you can rest assured they are benefiting from the best comfort, energy efficiency, usability and service available on the market. Stand By Me eliminates your clients' worries and provides them with a free, extended warranty, quick follow-up from Daikin service providers, and additional warranties for specific parts.



Free warranty extension



The first advantage of **Stand By Me** is a free warranty extension:

- applies to both labour and parts
- begins immediately after registration



Quick follow-up by Daikin service partners

Daikin service partners are automatically notified when a customer registers their installation on www.standbyme.daikin.eu and needs maintenance.

Your customer is guaranteed:

- quick and reliable service
- management of all information related to their installation such as, registration documents, attendance records, maintenance records, etc.
- realtime error codes are informing the service partner about possible issues



Extended warranty on parts

For a small fee, customers can extend the warranty on specific parts. Contact your local Daikin branche to have more information about the specific offer in your country. **Stand By Me** guarantees:

- that each component is replaced quickly
- helps avoid financial surprises
- long life and smooth operation and all other benefits of a Daikin installation
- reliable service from official Daikin service partners

Daikin service partners work exclusively with Daikin parts and have all of the necessary technical knowledge to solve any issue that may arise.

Stand By Me roadmap overview

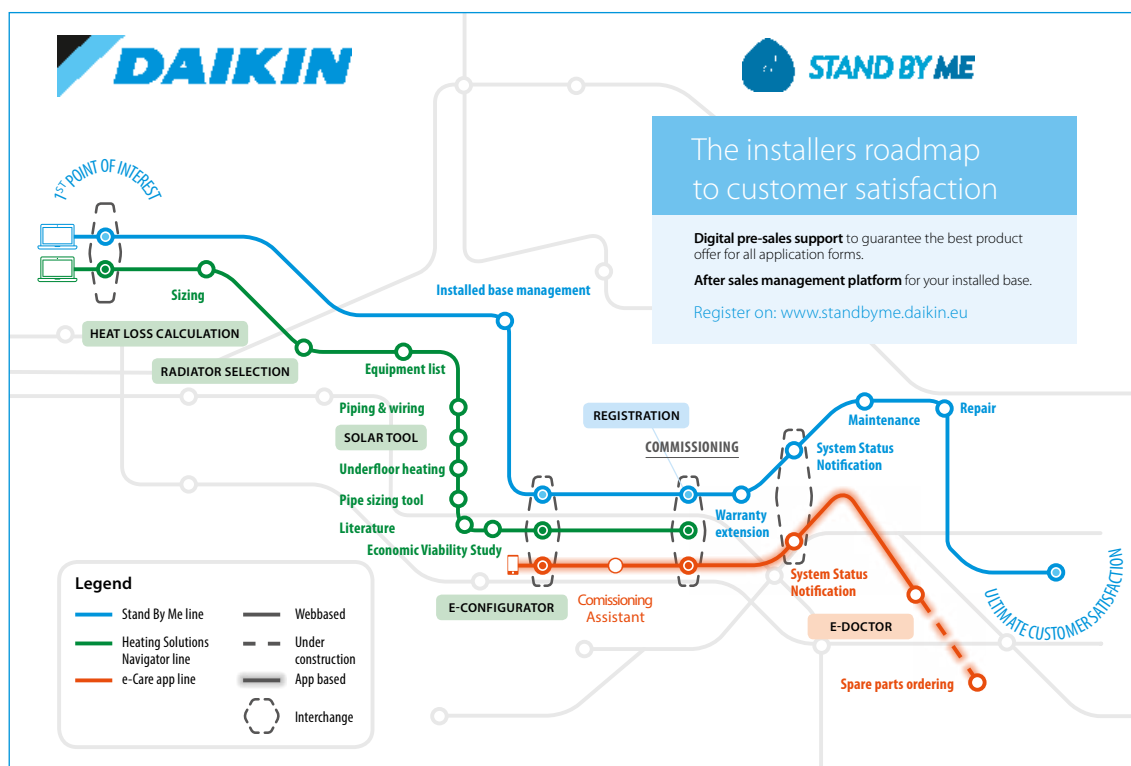

Heating Solutions Navigator



Want to know more about our Heating Solutions Navigator?

- › The Heating Solutions Navigator is a digital toolbox developed for Daikin professionals with the aim to assist in providing the best fit solution for your customers home.
- › With this tool you can configure your installation, create custom made piping & wiring diagrams, set the configuration on your installation and much more.

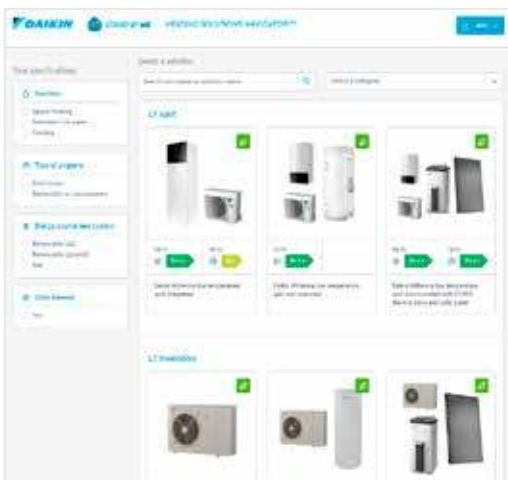

E-Care app



The Daikin e-Care app wants to make the life of a Daikin installer easier by offering Stand By Me registrations via QR code scanning, easy configuration of your heating installation and troubleshooting via the e-Doctor part.





Stand By Me and the Heating Solutions Navigator are built to connect between yourself and Daikin to make your life easier.

Interested in how the platform operates? Please scan the QR-codes to see a demo for each tool.



DEMO

SIZING

HSN Heat loss calculation tool/ Room by Room

The optional 'Room by Room' heat load calculation tool, is a tool which enable you to calculate the heat load in a property. Next to the Room by Room, a simplified heat load calculation is available.

SOLAR

HSN Solar Selection Tool

The Solar Selection Tool shows the benefits of a DAIKIN solar system and supports professionals in selecting the right solar system for a house.

PIPE SIZING TOOL

Calculate the maximum hydronic piping length from the indoor unit to the outdoor unit based on the emitter pressure drop or the other way around.

ECONOMIC VIABILITY STUDY

Compare your Daikin solution with a benchmark solution.

INSTALLED BASE MANAGEMENT



DEMO

HEATING SOLUTIONS NAVIGATOR (HSN)

professional.standbyme.daikin.eu

The Heating Solutions Navigator is a digital toolbox developed for Daikin professionals with the aim to assist in providing the best fit solution for your customers homes. With this tool you can configure your installation, create custom made piping & wiring diagrams, set the configuration on your installation and much more.



DEMO



DEMO

RADIATOR

HSN Radiator Selection Tool

This Radiator selector tool supports customers in selecting the appropriate radiator size for each room.

EQUIPMENT LIST

UNDERFLOOR HEATING

The underfloor Heating Tool gives the customer an indication of material that is needed for a specific project. A detailed calculation and floorplan can also be asked via this toolbox.

PIPING & WIRING

Customized piping and wiring diagrams are generated for each and every project, taking into account many parameters such as heat generator, zoning, emitter type and options.

CONFIGURATION TOOL

The e-Configurator is a web based tool and app which allows installers to configure the settings of Daikin Altherma heat pumps remotely. Thanks to its user friendly and intuitive interface, configuration can be completed in a couple of steps. Then it can be stored as a pdf or saved in the USB stick/ SD card to upload it in the heat pump on site.



DEMO

LITERATURE



DEMO



**CONTACT YOUR LOCAL
SBM/HSN SPECIALIST**

REGISTRATION

Installation Registration SBM is an after-sales service tool where end-users can extend the warranty on their installation or order maintenance packages. All Daikin professionals have an essential role in these service offerings.

With Stand By Me, you, as Daikin professional, can keep a complete digital logbook of your installed base of Daikin products and consult it via any mobile device.

COMMISSIONING

COMMISSIONING ASSISTANT

Use this special hydro check module during commissioning.



DEMO

WARRANTY EXTENSION

SYSTEM STATUS NOTIFICATION

SYSTEM STATUS NOTIFICATION

Receive malfunction codes of your installations directly on your Stand By Me platform or via a notification in the e-Care app.

MAINTENANCE



DEMO

E-DOCTOR

Part of e-Care
Daikin e-Doctor is part of e-Care, an application to guide our Daikin colleagues and installers in troubleshooting a unit.

REPAIR

SPARE PARTS ORDERING

ULTIMATE CUSTOMER SATISFACTION

E-CARE



Stand By Me, a journey towards customer satisfaction

Combination table and options

Combination table and options			Wall mounted		
			H/O (White)	Reversible (White)	
			ETBH16DA6V	ETBX16DA6V	
			ETBH16DA9W	ETBX16DA9W	
Type	Description	Material name			
Outdoor unit		EPRA14DAV3/W1	●	●	
		EPRA16DAV3/W1	●	●	
		EPRA18DAV3/W1	●	●	
Controls	Wired room thermostat	BRC1HHDA*	●	●	
	Wired digital thermostat	EKWCTRD11V3	●	●	
	Wired analog thermostat	EKWCTRAN1V3	●	●	
	Valve actuator	EKWCVATR1V3	●	●	
	Wired underfloor heating base station	EKWUFHTA1V3	●	●	
	LAN Adapters + APP		BRP069A61	●	●
			BRP069A62	●	●
W-LAN adapter (Module / Cartridge)		BRP069A71 / BRP069A78	●	●	
Heat pump convector	Floor standing	FWXV10-15-20ATV3	●	●	
	Wall mounted	FWXT10-15-20ATV3	●	●	
	Concealed	FWXM10-15-20ATV3	●	●	
Domestic hot water tank	Stainless steel tank	EKHWS(U)150D3V3	●	●	
		EKHWS(U)180D3V3	●	●	
		EKHWS(U)200D3V3	●	●	
		EKHWS(U)250D3V3	●	●	
		EKHWS(U)300D3V3	●	●	
	Polypropylene tank	EKHWP300B	● (1)	● (1)	
		EKHWP500B	● (2)	● (2)	
		EKHWP300PB	● (1)	● (1)	
		EKHWP500PB	● (2)	● (2)	
	Third party tank kit	EKHY3PART	● (3)	● (3)	
		EKHY3PART2	● (4)	● (4)	
	Options	Bi-zone kit	BZKA7V3	●	●
		Remote indoor sensor	KRCS01-1	● (5)	● (5)
Remote outdoor sensor		EKRSCA1	● (5)	● (5)	
PC USB cable		EKPCCAB4	●	●	
Universal centralized controller		EKCC8-W	●	●	
Digital I/O PCB		EKRPIHBAA	● (6)	● (6)	
Demand PCB		EKRPIAHTA	●	●	
Freeze protection valve		AFVALVE1	●	●	
Conversion kit H/O => reversible			EKHBCONV	●	
		EKHVCONV2			
Dedicated options for ECH ₂ O unit	Backup heater switch box	EKBUSWB			
	Backup heater 1kW	EKBUB1C			
	Backup heater 3kW	EKBUB3C			
	Backup heater 9kW	EKBU9C			
	Room thermostat	EHS157034			
	Mixer module	EHS157067			
	Optional outdoor sensor	EKRSC1			
	Gateway for Apps	EHS157056			
	Hydraulic separator	172900			
	Heat insulation for HWC	172901			
	Pump group with mixer module	156075			
	Pump group without mixer module	156077			
	Connection kit for MK1	156053			
	Dirt separator SAS1	156021			
	Dirt separator SAS2	156023			
	Biv Connector Kit	141589			
	DB connector Kit	141590			
Terminal connection kit	141592				
Connector external heater	141591				

(1) Dedicated connection kit: EKEPHT3H

(2) Dedicated connection kit: EKEPHT5H (3) EKHY3PART can be used if you have a tank in which you can insert the thermistor
(4) EKHY3PART2 can be used if you have a tank in which you can't insert a thermistor

(5) Only 1 sensor can be connected: indoor OR outdoor sensor

(6) Additional relays to allow bivalent control in combination with external room thermostat are field supply.



Daikin Europe N.V. Naamloze Venootschap Zandvoordestraat 300 · 8400 Oostende · Belgium · www.daikin.eu · BE 0412 120 336 · RPR Oostende (Publisher)

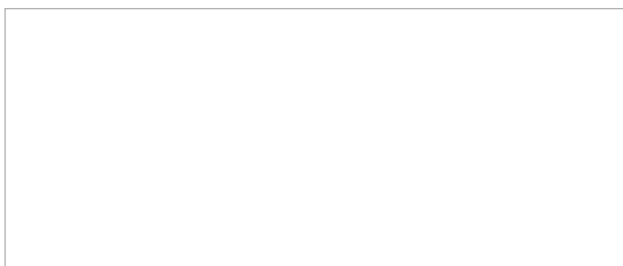

ECPEN19-767

12/19



The present publication is drawn up by way of information only and does not constitute an offer binding upon Daikin Europe N.V. Daikin Europe N.V. has compiled the content of this publication to the best of its knowledge. No express or implied warranty is given for the completeness, accuracy, reliability or fitness for particular purpose of its content and the products and services presented therein. Specifications are subject to change without prior notice. Daikin Europe N.V. explicitly rejects any liability for any direct or indirect damage, in the broadest sense, arising from or related to the use and/or interpretation of this publication. All content is copyrighted by Daikin Europe N.V.

Printed on non-chlorinated paper.